

APPENDIX A
SMALL PROJECT APPLICATION

File Number _____

Date Received _____

Submitted Fees \$ _____

Approval of Application Date _____

Project Street Address: _____

Project Name: _____

Owner's Name and Address: _____

Phone# / Fax# / Email: _____

Please list the date of any previous Small Project Applications for the subject property:

Proposed Activity:

Removal of ground cover, grading, filling or excavation of an area less than 5,000 square feet

Total area of land disturbance: _____ sq. ft.

Type of Regulated Activity (check all that apply):

- Removal of ground cover
- Grading
- Filling
- Excavation
- Other earth disturbance activity (please describe)

Addition of Impervious Surface (more than 1,000 SF but less than 5,000 SF)

Type of new impervious surface: driveway, shed, garage, deck, walkway,

other (describe) _____

Total new impervious surface proposed for construction: _____ sq. ft.

Are you removing existing impervious as part of this project?

- No
- Yes – Total area of existing Impervious to be removed _____ sq. ft.

Check all items below that will be impacted by the project:

- _____ Mature trees
- _____ Sinkholes
- _____ Water wells
- _____ Septic drainfields
- _____ Alternate septic drainfields
- _____ Creeks, streams, wetlands, or ponds
- _____ Existing stormwater management facility (basin, swale, etc.)
- _____ Easements

Small Project Application Pg. 2

Total runoff volume to be permanently removed/managed on site from attached calculation worksheet: _____ gallons or _____ cubic feet

Proposed Stormwater Management Controls (Best Management Practice):

- _____ Rain Garden
- _____ Infiltration Trench
- _____ Cistern
- _____ Rain Barrel
- _____ Other (describe) _____

Sketch

Provide a sketch of the proposed additional impervious area or land disturbance. Include the following on the sketch:

- Property boundary
- Location and approximate footprint of existing structures (buildings, patios, driveways, etc.)
- Approximate location of any of the following features which will be impacted by the project:
 - Mature trees
 - Sinkholes
 - Water wells
 - Septic drainfields
 - Alternate septic drainfields
 - Creeks, streams, wetlands, ponds
 - Existing stormwater management facilities (basins, swales, etc.)
- Location and approximate footprint of proposed impervious area or land disturbance.
- Approximate footprint and location of all structures on adjacent properties if located within fifty feet (50') of the proposed impervious area or land disturbance
- Location and description of proposed stormwater management facilities (e.g. rain gardens, swales, rain barrels, etc.)
- Direction of proposed stormwater discharge (e.g. with arrows)
- Scale and north arrow

Person/Firm to be completing work: _____

Phone# / Fax# / Email: _____

Name of Person Submitting this Application: _____

Signature: _____

Date: _____

Small Project Application Calculation Worksheet

The applicant may use the following to calculate the amount of runoff which must be managed in accordance with Section 302.B of this Ordinance.

Project Name: _____

Owner Name: _____

Proposed Additional Impervious Area: _____ square feet

Impervious Area Calculations

Calculate the amount of runoff to be permanently removed (managed on site through reuse, evaporation, transpiration or infiltration):

Additional impervious area ÷ 12 = Permanently Removed Runoff Volume (PRV)

_____ square feet of additional impervious ÷ 12 = _____ cubic feet PRV

_____ cubic feet x 7.48 gallons per cubic feet = _____ gallons PRV

CUBIC FEET PRV (FROM PAGE 62) = _____ (PRV)
 CISTERN VOLUME REQUIRED = PRV X 2.5 = _____ (CVR)
 CISTERN VOLUME PROVIDED (cir) = W X W X D X 0.8 = _____ (CVP)
 OR CISTERN LENGTH (SQUARE CISTERNS ONLY, TYP. = TO W) _____
 CISTERN VOLUME PROVIDED (sq) = L x W x D = _____ (CVP)

CVP must exceed CVR

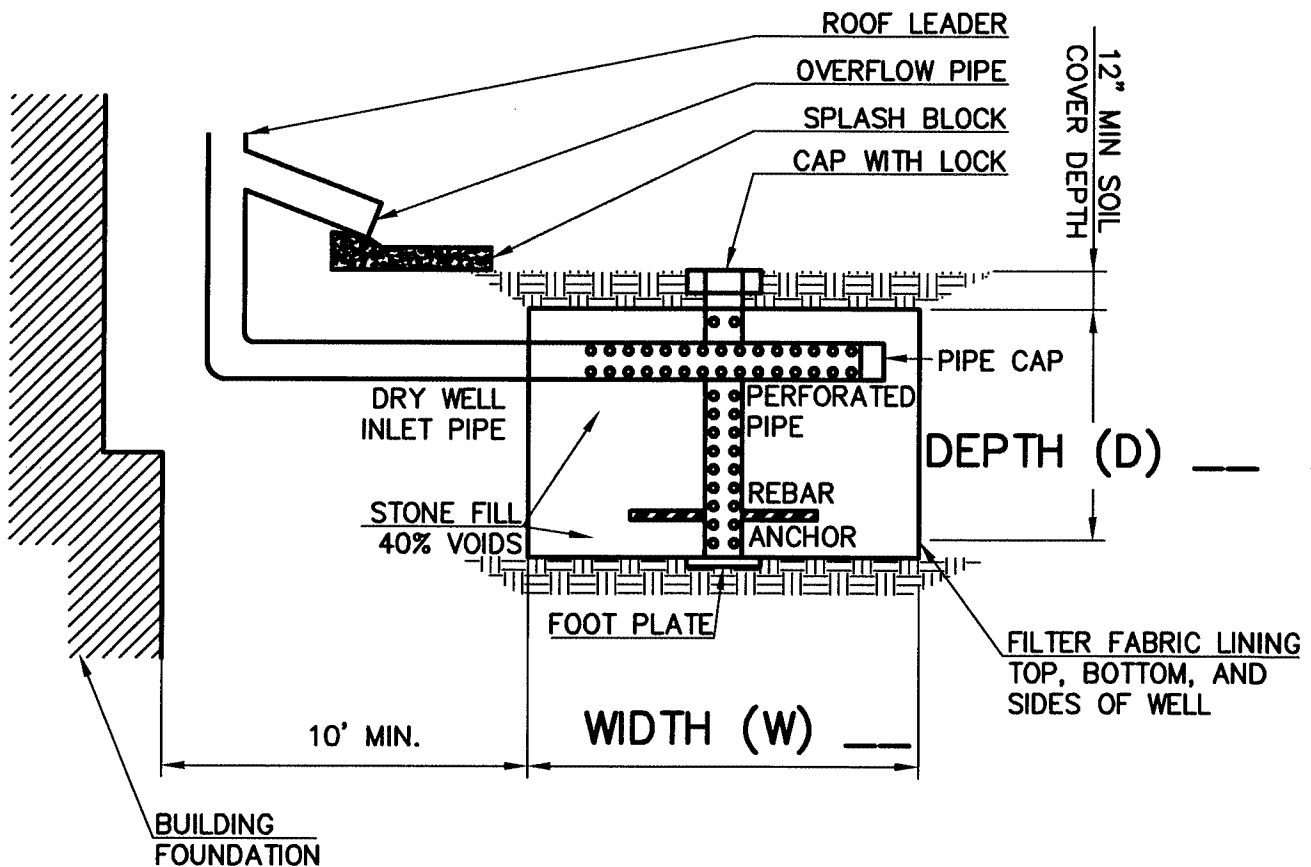

CONESTOGA TOWNSHIP

SWM SCHEMATIC DIAGRAMS
 FOR SMALL PROJECTS
 SQUARE OR CIRCULAR CISTERN

Engineering Services By:

WC
GROUP

WILSON CONSULTING GROUP, P.C.
 100 OLD SCHOOLHOUSE LANE
 MECHANICSBURG, PA 17055
 www.wcg-pc.com 717.591.3070

CUBIC FEET PRV (FROM PAGE 62) = _____(PRV)
 BED VOLUME REQUIRED = PRV x 2.5 = _____(BVR)
 BED DEPTH _____

BED VOLUME PROVIDED = L x W x D = _____(BVP)

BVP must exceed BVR

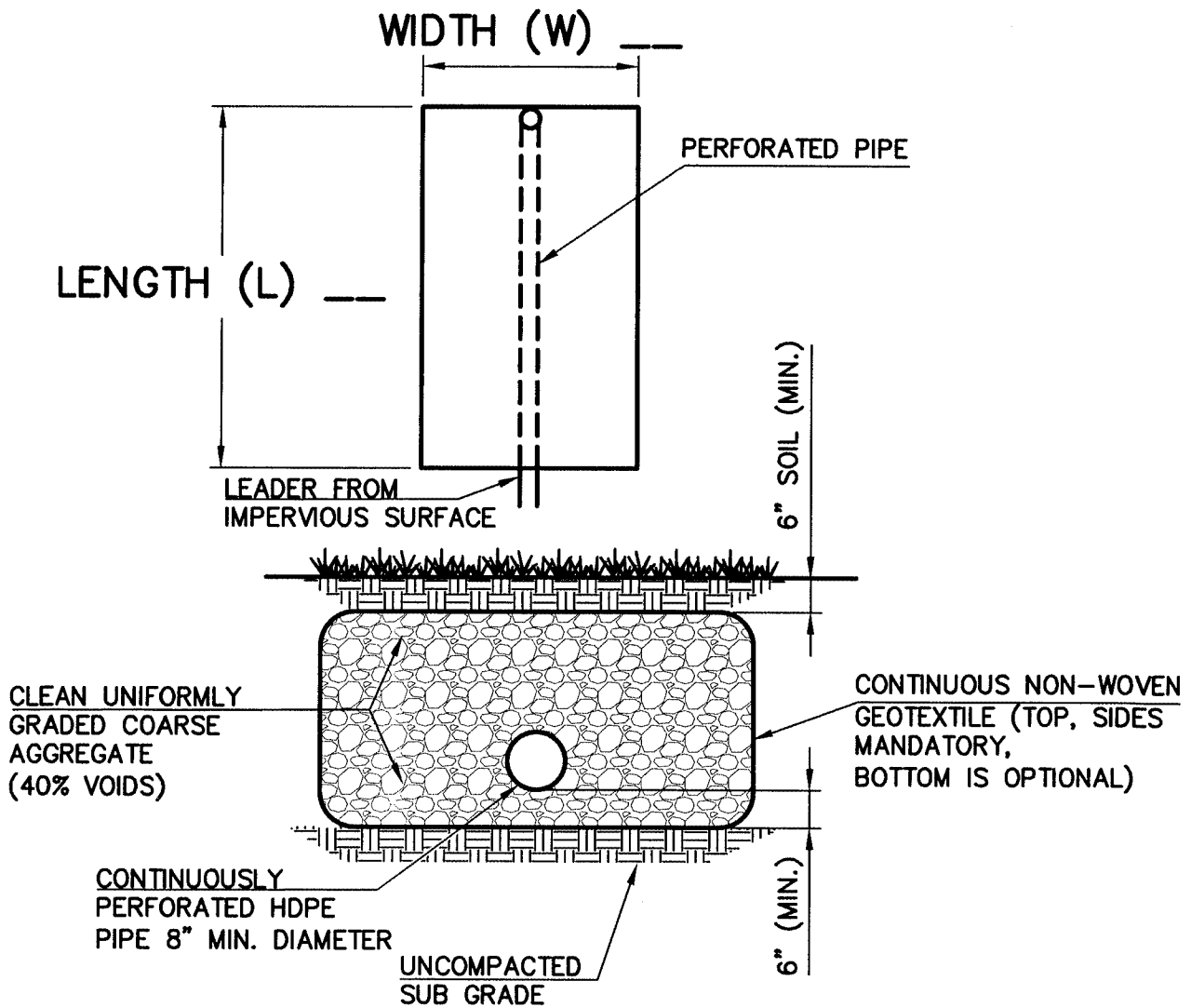

CONESTOGA TOWNSHIP

**SWM SCHEMATIC DIAGRAMS
 FOR SMALL PROJECTS
 INFILTRATION TRENCH**

Engineering Services By:



WILSON CONSULTING GROUP, P.C.
 100 OLD SCHOOLHOUSE LANE
 MECHANICSBURG, PA 17055
 www.wcg-pc.com 717.591.3070

NUMBER OF BARRELS REQUIRED =
SQ. FT. OF NEW IMPERVIOUS SURFACE / 750, ROUNDED UP. _____.

IF COMMERCIALLY AVAILABLE RAIN BARREL(S) IS(ARE) USED, INCLUDE
MANUFACTURERS INFORMATION FOR BARRELS.

OTHERWISE, PROVIDE SCHEMATIC DRAWINGS OF HOME-MADE RAIN
BARREL(S).

FOLLOW ALL MANUFACTURERS INSTRUCTIONS FOR MAINTENANCE.

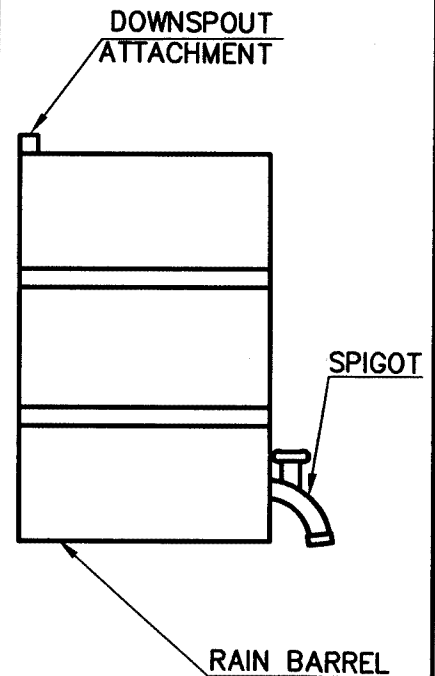

CONESTOGA TOWNSHIP

**SWM SCHEMATIC DIAGRAMS
FOR SMALL PROJECTS
RAIN BARREL**

Engineering Services By:

WC
GROUP

WILSON CONSULTING GROUP, P.C.
100 OLD SCHOOLHOUSE LANE
MECHANICSBURG, PA 17055
www.wcg-pc.com 717.591.3070

CUBIC FEET PRV (FROM PAGE 62) = _____(PRV)
 GARDEN VOLUME REQUIRED = PRV = _____(GVR)
 GARDEN VOLUME PROVIDED = L x W / 1.5 = _____(GVP)

GARDEN DEPTH (18" MAX) _____.

GVP must exceed GVR

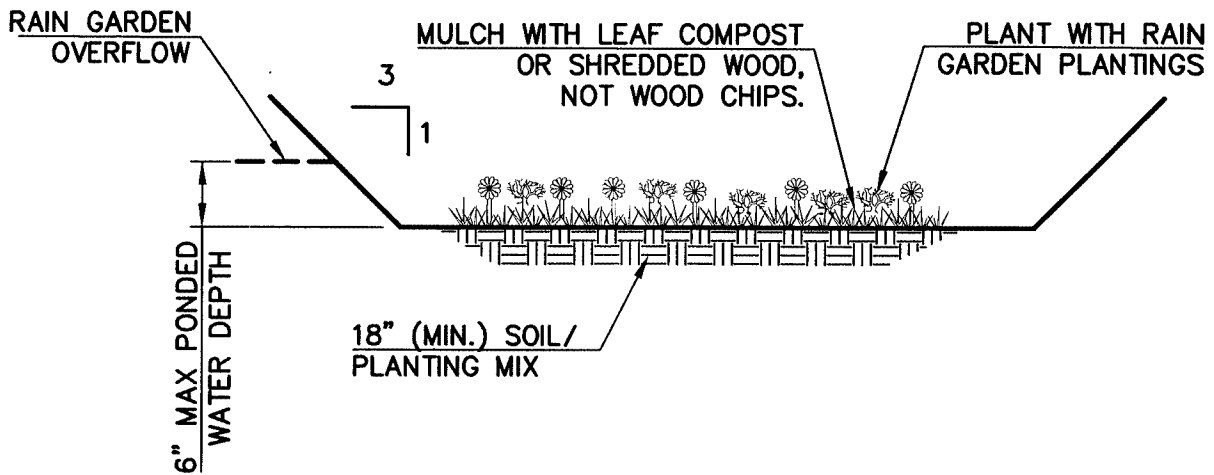
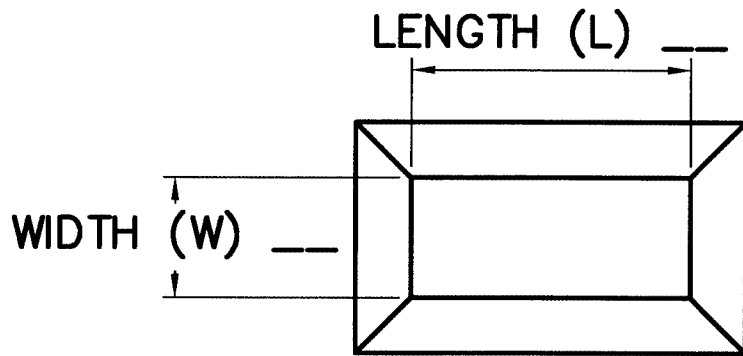

CONESTOGA TOWNSHIP

SWM SCHEMATIC DIAGRAMS
 FOR SMALL PROJECTS

RAIN GARDEN

Engineering Services By:



WILSON CONSULTING GROUP, P.C.
 100 OLD SCHOOLHOUSE LANE
 MECHANICSBURG, PA 17055
 www.wcg-pc.com 717.591.3070

